

Anionic and cationic surfactant recovery from water using a multistage foam fractionator

Savanit Boonyasuwat^{a,*}, Sumaeth Chavadej^a, Pomthong Malakul^a, John F. Scamehorn^b

^a *The Petroleum and Petrochemical College, Chulalongkorn University, Bangkok 10330, Thailand*

^b *Institute of Applied Surfactant Research, The University of Oklahoma, Norman, OK 73019, USA*

Accepted 29 January 2003

Abstract

Surfactants can be present at low concentrations in effluent wastewater from various industrial operations. Also, the increasing use of surfactant-based separations results in surfactants in water generated by these separations. The surfactant concentration must sometimes be reduced in order to meet environmental standards in discharging these waters to the environment. Also, recovery of the surfactant for reuse is sometimes economical and desirable. Foam fractionation has been shown to be an effective method of removing anionic or cationic surfactants from water in a single stage in previous works. In this study, the recovery of a cationic surfactant (cetylpyridinium chloride, CPC) and an anionic surfactant (sodium dodecylsulfate, SDS) from water by multistage foam fractionation in a bubble-cap trayed column was investigated with one to four stages operated in steady-state mode for surfactant concentrations less than the critical micelle concentration (CMC). In a previous study of a single-stage foam fractionator, CPC was shown to be effectively removed from water, and in agreement with this study. In this study, multiple trays are investigated. Enrichment ratios as high as 120.23 were observed and increased with decreasing superficial air flow rate, increasing foam height of the top tray, increasing feed liquid flow rate, decreasing feed surfactant concentration, and increasing number of stages. The fractional surfactant removal can be as high as 100% and increases with decreasing air flow rate, increasing foam height per tray, increasing feed liquid flow rate, increasing feed surfactant concentration, and increasing number of stages. Scale-up of foam fractionation for recovery or removal of surfactant from water to a multi-tray column was successful.

© 2003 Elsevier Science B.V. All rights reserved.

Keywords: Anionic and cationic surfactant recovery; Multistage foam fractionator; Critical micelle concentration

1. Introduction

Surfactants are widely used in many industries or present in manufactured products such as detergents, personal care products, food industry, fire fighting, ore flotation, and many others [14]. As environmental regulations tighten, there is increasing concern about reducing the surfactant concentration in effluent streams. One source of these streams is generated from surfactant-based separation processes, which have increasingly been used to remove pollutants from wastewater and groundwater. In addition to satisfying environmental regulations, the value of the surfactant being emitted sometimes make recovery operations more economical. An alternative approach to the biodegradation of the surfactant is the direct treatment of the rinsing waters by physical separation that would allow for the reuse of both water and surfactant. Many wastewaters contain very low surfactant concentra-

tions, around or below the critical micelle concentrations (CMC).

In the present study, removal of surfactant, cetylpyridinium chloride (CPC) from water is studied in a pilot unit with from one to four trays.

Foam fractionation is a process in which solute species adsorbs at the gas–liquid interface between a dispersed phase (gas bubble) and a continuous phase (bulk liquid). Foam fractionation is an example of a surfactant-based separation, a major class of separations [10]. Foam fractionation processes have been used to concentrate and remove surface-active agents from aqueous solutions [5,12]. Foam fractionation has proven to be extremely effective at removing contaminants from wastewater streams [14]. The foam which forms at the surface is allowed to drain and once collapsed, to form a concentrated liquid that can be recycled in the production process as shown in Fig. 1. Moreover, non-surface-active materials can be also removed by interaction with the surfactant and are carried along into the foam [5]. In the latter case, the surfactant is called a collector [1]. In foam fractionation, air is sparged to produce

* Corresponding author.

E-mail address: boonyasuwat@hotmail.com (S. Boonyasuwat).

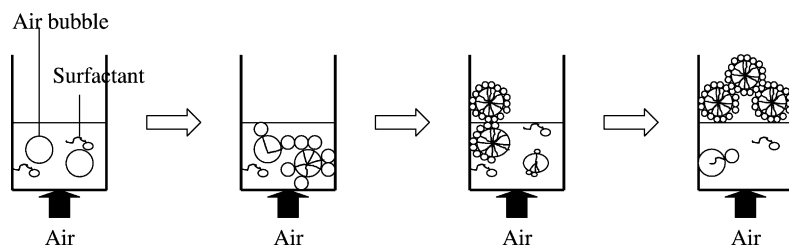

Fig. 1. Principle of foam fractionation [11].

bubbles which rise to the top of liquid column producing foam. As the bubbles travel through the continuous phase, surfactant adsorbs at the air–liquid interface. When the air bubble emerges from the liquid, it forms a cell in the foam matrix with a honeycomb structure. The thin liquid film between the air bubbles (foam lamellae) is stabilized by the adsorbed surfactant [2,3]. The liquid drains from the lamellae due to gravity and Plateau Border suction effects causing the foam to eventually break or collapse [8]. The collapsed foamate solution is much more concentrated in the surfactant than in the initial solution.

There are two modes of foam fractionation, simple mode (batch wise or continuous), and higher mode with enriching and/or stripping [7]. The foam fractionation column can also be classified into two categories; single stage and multistage as shown in Fig. 2. Foam fractionation has been extensively studied for the purpose of removing pollutants (e.g. heavy metals) from water by adding surfactant [6]. Several studies have also been done to investigate recovery of the surfactant itself using foam fractionation and to examine the effects of various parameters on the separation efficiency of surfactants and proteins [8]. However, most of these studies have to use either batch or continuous mode on single-stage flotation columns whereas the use of multistage pilot plants has seldom been reported [5,12,13]. Many variables were considered to have a significant effect upon removal efficiency, such as the height of the foam–liquid interface, the air flow rate, the bubble diameter, and the feed concentration but the effect of added electrolyte has received little attention [14]. In our previous studies, the effects of air flow rate, foam

height, liquid height, surfactant feed concentration, temperature, added electrolyte, and sparger porosity on the recovery of the cationic surfactant, cetylpyridinium chloride, and several anionic surfactants were studied using a single-stage foam fractionator [12].

In this present study, we designed and built a multistage foam fractionator in our laboratory and investigated a continuous operation of the multistage column in the recovery of CPC from aqueous solution. The investigation involved a systematic study of the effects of several important variables such as air flow rate, foam height, surfactant feed concentration and the number of stage on the separation efficiency of CPC and sodium dodecylsulfate (SDS). One of the main objective of this study was to demonstrate that the multistage foam fractionation system could operate without problems like excessive pressure drop or flooding and enhance the separation efficiency of CPC and SDS as compared to a single-stage system.

2. Experimental procedure

2.1. Materials

Cetylpyridinium chloride (>99% pure, Zealand Chemical), a cationic surfactant, sodium dodecylsulfate (96.28% SDS, 1.12% volatile matter, 0.39% *n*-hexane, 2.207% SO₄) were used as received. Freshly deionized water was used in all experiments.

2.2. Equipment setup

A schematic diagram of the multistage foam fractionation unit used in this study is shown in Fig. 3. The multistage foam fractionation column comprised a jacketed stainless steel cylinder having a jacket diameter of 30 cm and internal column diameter of 20 cm and tray spacing of 15 cm. Bubble-cap trays were used with 16 bubble caps per tray with a weir height of 5 cm and a cap diameter of 2.5 cm. A sample port was located at the base of the each tray for taking liquid samples. Three foam heights of 30, 60 and 90 cm from the top tray of the column were studied. Fig. 4 illustrates the process flow diagram for the experimental pilot plant.

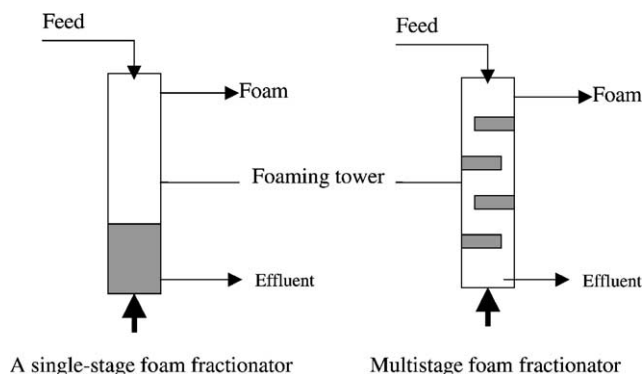

Fig. 2. Foam fractionator separating columns.

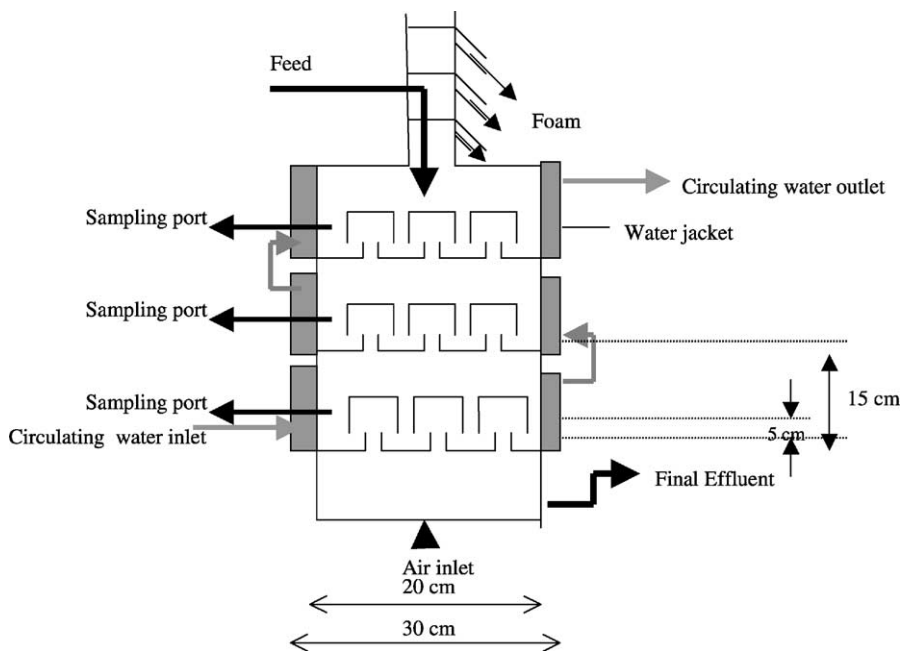

Fig. 3. Diagram multistage foam fractionation column with three trays.

2.3. Methods

The foam fractionation system was performed in continuous flow operation with aqueous solution containing different surfactant concentrations. The surfactant feed solution was continuously pumped by a peristaltic pump at flow rates in a range of 25–200 ml/min ($0.7215\text{--}5.77\text{ l}/(\text{min m}^2)$) and entered the column at the top position of the highest tray. The pressurized air flow rate was measured by a rotameter over a range of 30–100 l/min and was introduced to the bottom of the column. The column operating temperature was held constant at 25 °C by using a circulating cooling–heating bath to circulate water through the water jacket around the column. After a designated time interval, the foamate at the

top of the solution was collected at three different heights (30, 60 and 90 cm) from the top of the column. The foam collected was frozen, thawed, and then weighted to measure the mass and volume of the collapsed foamate at room temperature over a period of about 20 h to determine the time to establish steady-state. Samples of the feed solution, the collapsed foamate and the effluent were analyzed for surfactant concentration. The column was thoroughly cleaned with distilled water before starting the next experiment. All of the experiments were performed at least three times to ensure reproducibility of the results and the mean values reported.

The foam fractionation was studied under steady-state condition. To obtain steady-state, the experiment was carried out for a minimum of 20 h compared to 6 h in previous study,

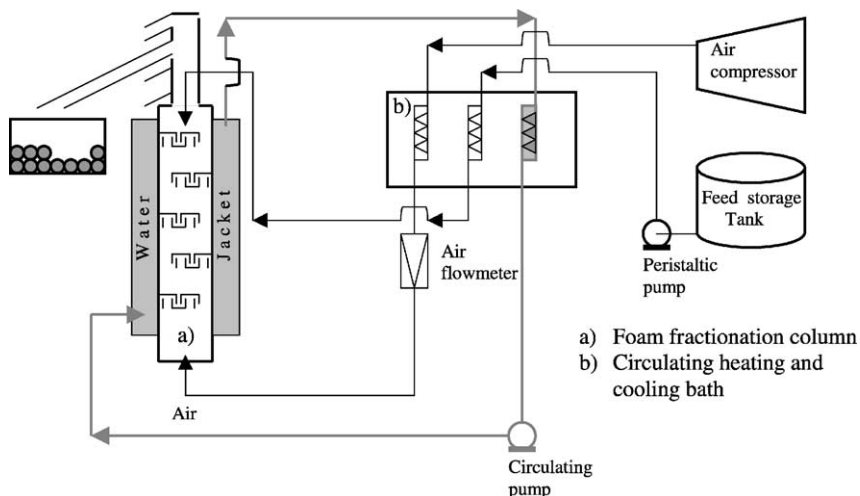

Fig. 4. Schematic diagram of multistage foam fractionation system.

this due to the size of the fractionation column. Steady-state was ensured when all measured parameters were invariant with time. In each experiment, foam wetness (g of foam solution/l of foam) and the surfactant concentration (g/l) in the collapsed foam solution were measured. The concentration of CPC was measured by a UV-Vis spectrophotometer at 260 nm (Perkin-Elmer, Lambda 10). The CMC of the surfactant was calculated from the concentration where the specific surface tension versus surfactant concentration showed an abrupt change in the slope.

3. Results and discussion

Under the base conditions, the foam fractionation system was found to reach steady-state within approximately 20 h where the surfactant concentrations measured on each tray were relatively constant. Effects of several parameters on the separation efficiency of the multistage fractionator operated in a continuous mode were studied and evaluated using the removal fraction and the enrichment ratio as shown below:

$$\text{Removal fraction} = \frac{C_i - C_e}{C_i} \quad (1)$$

$$\text{Enrichment ratio} = \frac{C_f}{C_i} \quad (2)$$

where C_i and C_e are surfactant concentrations (mg/l) in the influent and effluent streams, respectively, and C_f the surfactant concentration in the collapsed foam.

It was found that the mass balance for surfactant closed within at least 90% for all runs.

3.1. Effect of air flow rate

The effect of the air flow rate on the enrichment ratio and removal fraction is shown in Fig. 5. To interpret the efficiency of this multistage foam fractionator, the foam wetness was measured and shown in Tables 1–3. The lowest air flow rate used in this part of the study was very close to

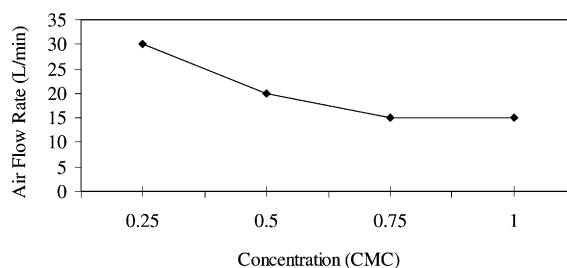

Fig. 5. The effect of air flow rate on surfactant separation efficiency at different feed concentrations and foam heights (feed flow rate, 25 ml/min; and number of stages, 3).

Table 2
Enrichment ratio and foam wetness on influence of feed concentration

Influent concentration (CMC)	Enrichment ratio	Removal fraction	Foam wetness
0.25	117.6	0.9	0.83
0.50	75.8	1.0	1.94
0.75	44.4	1.0	2.70
1	37.6	1.0	2.93

Conditions: air flow rate, 30 l/min; foam height, 60 cm; number of stages, 3; and feed flow rate, 50 ml/min.

the lowest flow rate possibly used for this multistage foam fractionator since any flow rate lower than this resulted in such a low production of foam that the foam being produced would collapse before reaching the overflow pipe.

Fig. 5 illustrates that increased air flow rate results in a reduction in the enrichment ratio as well as the removal fraction. The enrichment ratio is higher when as the foam is dried at lower air flow rate because the higher residence time of bubbles in the rising foam permits drainage of water in the lamellae, leaving dry foam with a higher surfactant concentration. This is due to a substantial fraction of the surfactant in the foam being adsorbed at the air–water interface rather than in the lamellae liquid which drains off. An increase in air flow rate results in a higher volumetric rate of foam and a wetter foam, thus leading to a lower enrichment ratio of

Table 1
Experimental results for foam fractionation runs at different air flow rates

Influent concentration (CMC)	Foam height (cm)	Enrichment ratio				Removal fraction				Foam wetness (g/l)			
		30 l/min	50 l/min	80 l/min	100 l/min	30 l/min	50 l/min	80 l/min	100 l/min	30 l/min	50 l/min	80 l/min	100 l/min
0.25	90	– ^a	– ^a	– ^a	27.88	– ^a	– ^a	– ^a	0.7833	– ^a	– ^a	– ^a	3.59
	60	120.23	89.23	49.39	25.54	0.887	0.8434	0.8735	0.7488	0.72	1.43	2.55	4.01
	30	36.97	44.29	5.93	6.41	0.6354	0.6330	0.5593	0.6041	3.51	2.77	35.55	29.58
0.50	90	– ^a	51.17	30.44	13.23	– ^a	0.8953	0.5434	0.5346	– ^a	2.48	3.37	19.45
	60	53.60	44.71	26.14	10.28	0.8758	0.8452	0.4915	0.4351	2.14	2.66	4.11	22.00
	30	40.45	27.49	6.94	4.44	0.8432	0.7081	0.3966	0.4014	3.04	4.03	33.74	38.02
0.75	90	– ^a	45.58	28.86	7.43	– ^a	0.8481	0.6459	0.5014	– ^a	2.53	3.93	30.09
	60	42.74	39.85	24.16	5.23	1.00	0.8312	0.5202	0.5001	2.87	3.67	4.98	38.46
	30	30.72	13.32	2.23	1.67	1.00	0.7722	0.4845	0.2640	3.77	17.99	60.43	69.44
1	90	– ^a	22.92	9.61	4.35	– ^a	0.9092	0.5460	0.4430	– ^a	4.21	26.66	40.04
	60	38.21	22.89	7.96	2.44	1.00	0.9081	0.5341	0.5771	2.89	4.63	30.31	58.76
	30	29.27	9.93	1.72	1.84	1.00	0.8045	0.4256	0.3599	3.90	26.46	67.77	66.90

^a The bubble could not reach overhead pipe.

Feed conc. = 0.25*CMC and Foam height = 30 cm

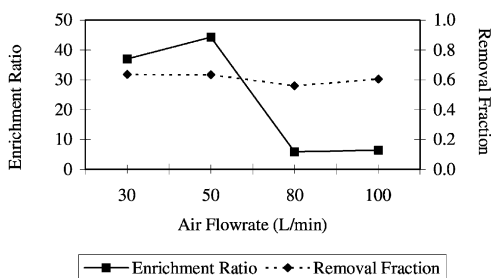

Feed conc. = 0.25*CMC and Foam height = 60 cm

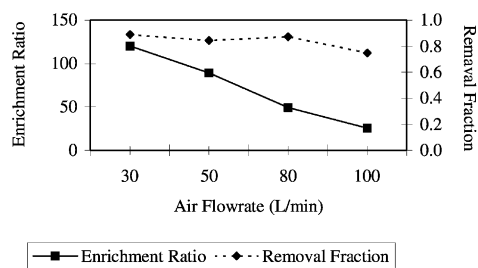

Feed conc. = 0.5*CMC and Foam height = 30 cm

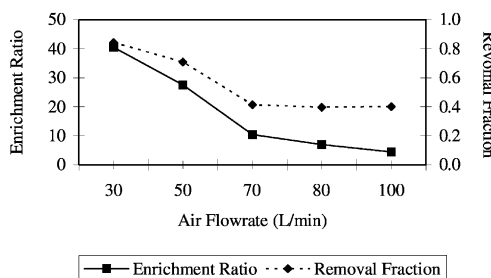

Feed conc. = 0.5*CMC and Foam height = 60 cm

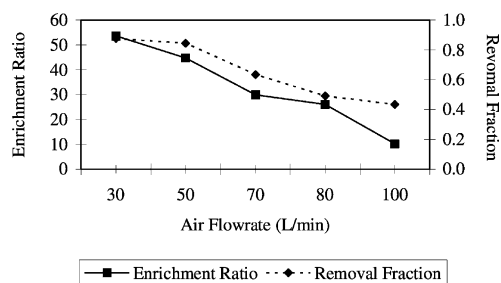

Feed conc. = 0.75*CMC and Foam height = 30 cm

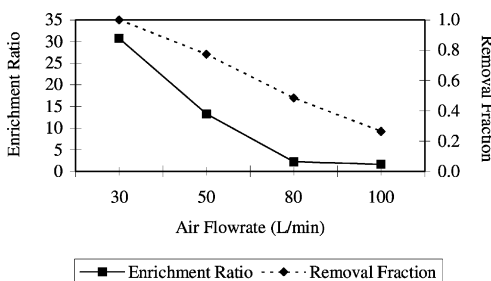

Feed conc. = 0.75*CMC and Foam height = 60 cm

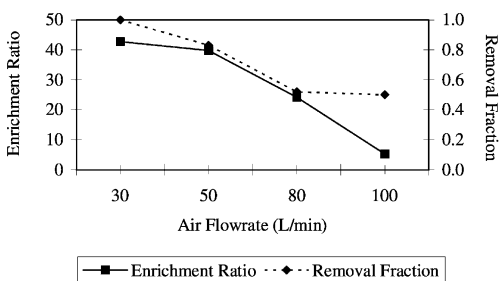

Feed conc. = 1*CMC and Foam height = 30 cm

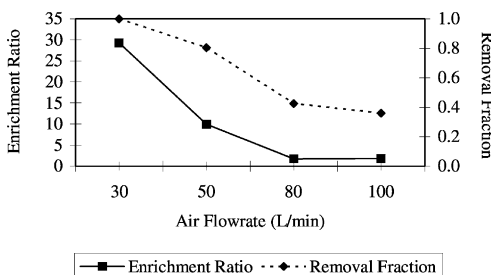

Feed conc. = 1*CMC and Foam height = 60 cm

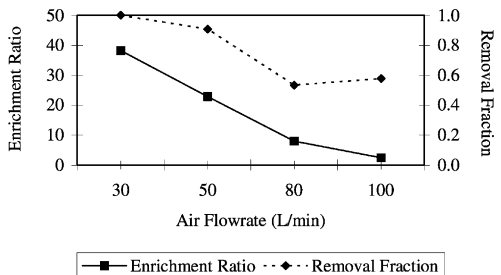

Fig. 6. The minimum air flow rate required for different conditions.

CPC. An increase in air flow rate tends to break the foam as well as to produce wetter foam. Therefore, the removal fraction of CPC decreases with increasing the air flow rate. The observed effect of air flow rate is in good agreement with other studies [4,11]. On Fig. 6, the graph indicate where the operating area is for each experimental runs.

3.2. Effect of foam height

As can be seen from Fig. 7, the removal fraction and the enrichment ratio of surfactant both increase with increasing the foam height. An increase in foam height leads to a longer foam residence time, which allows more drainage

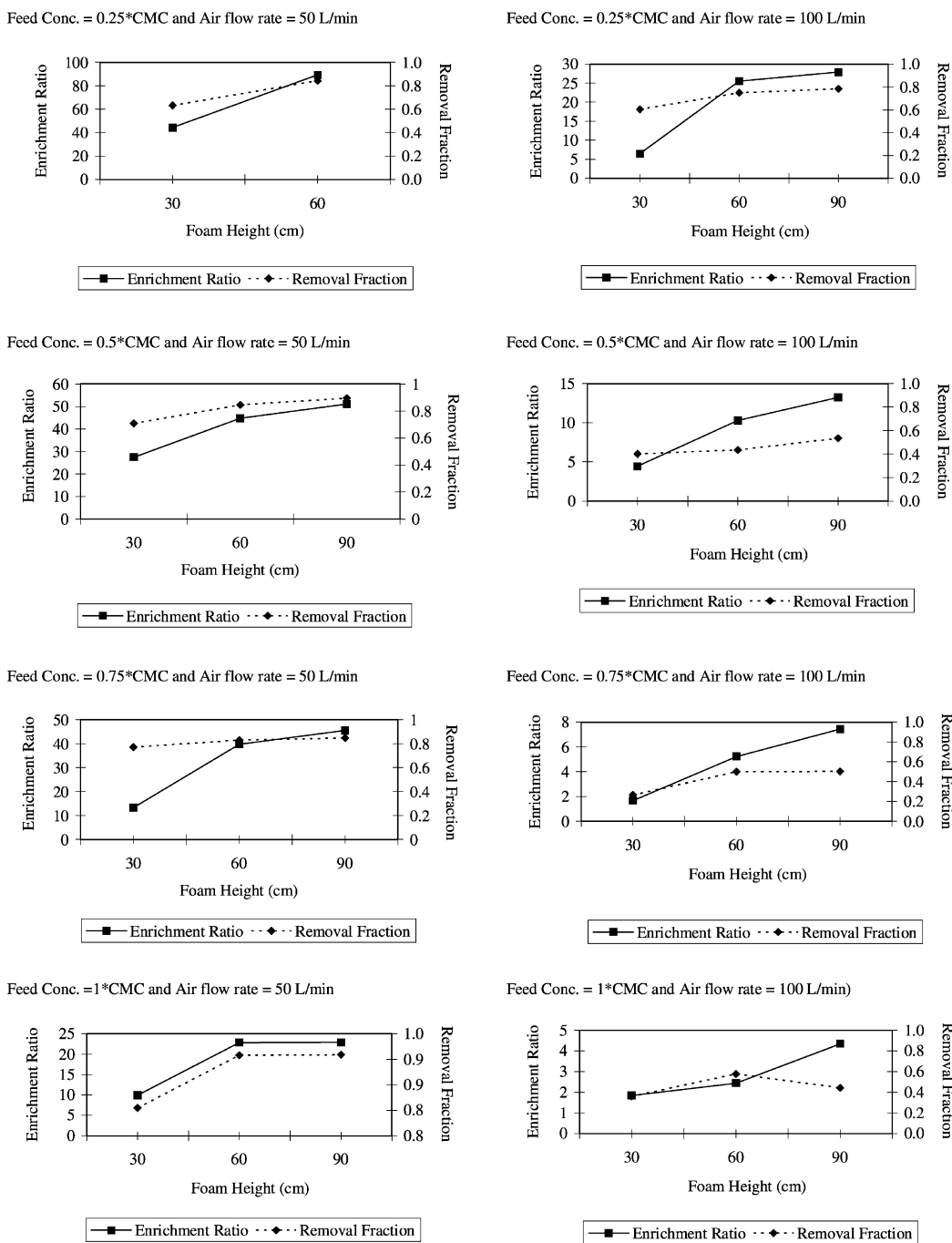

Fig. 7. The effect of foam height on surfactant separation efficiency at different feed concentrations and air flow rates (feed flow rate, 25 ml/min; and number of stages, 3).

of the liquid in the films. The dilution of the adsorbed surfactant molecules is lower as foam height increases, which in turn leads to higher enrichment ratio for the same reason discussed in the previous section.

3.3. Effect of liquid feed flow rate

The effect of the liquid feed flow rate is shown in Fig. 8. An increase in the flow rate of the liquid feed resulted in in-

creasing the enrichment ratio while the removal fraction remained constant around unity because the feed added stream is low thus increase the allowable of residence time on the liquid remaining in the column. The results indicated that the studied range of the feed flow rate was considerably low. Hence the surfactant concentration was completely removed and it was not possible to find effect of the liquid feed flow rate in this range. Since the system was operated at very low flow rates due to the liquid feed flow rate is not

Feed Conc. = 0.25*CMC and Foam height = 30 cm

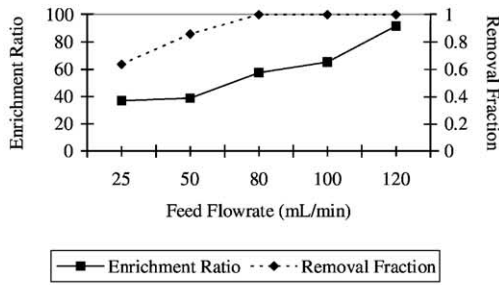

Feed Conc. = 0.25*CMC and Foam height = 60 cm

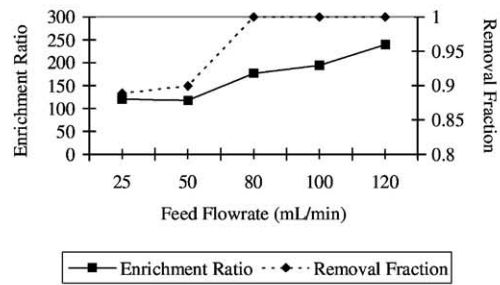

Feed Conc. = 0.5*CMC and Foam height = 30 cm

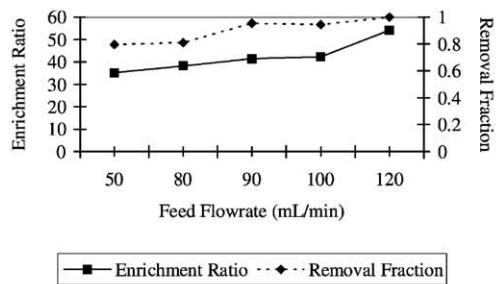

Feed Conc. = 0.5*CMC and Foam height = 60 cm

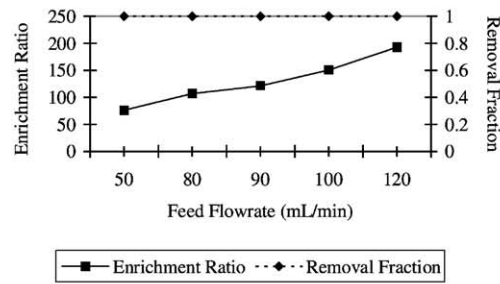

Feed Conc. = 0.75*CMC and Foam height = 30 cm

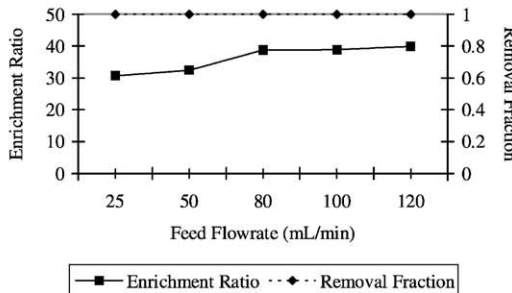

Feed Conc. = 0.75*CMC and Foam height = 60 cm

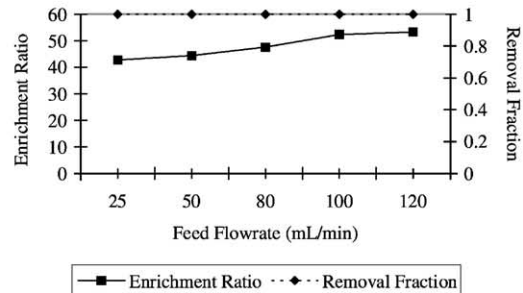

Feed Conc. = 1*CMC and Foam height = 30 cm

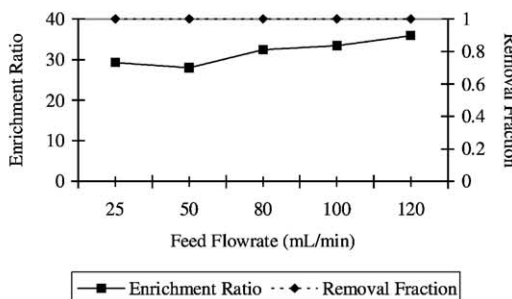

Feed Conc. = 1*CMC and Foam height = 60 cm

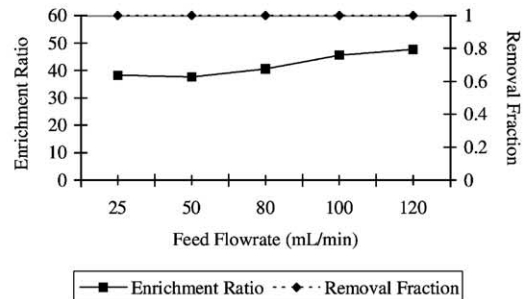

Fig. 8. The effect of liquid feed flow rate on surfactant separation efficiency at different feed concentrations and foam heights (air flow rate, 30l/min; and number of stages, 3).

compatible with air flow rates for this particular process. This result can be explain by the flooding mechanism with countercurrent air flow rate, a condition is reached with increasing air flow rate for which flow reversal occurs and liquid is carried upward. This have to controlled by flow

conditions at highest 120 ml/min liquid feed flow rate and at least for 30l/min air flow rate for three-stage fractionation column. Therefore, this present study has the limited operating area which avoid the flooding as can be seen in Figs. 9 and 10.

Table 3

Experimental results of anionic and cationic surfactants for foam fractionation runs^a

	Enrichment ratio		Removal fraction		Foam wetness	
	CPC	SDS	CPC	SDS	CPC	SDS
Air flow rate (l/min)						
30	53.6	22.34	0.8758	0.6430	2.14	0.20
40	46.82	22.04	0.8560	0.6520	2.22	0.20
50	44.71	20.55	0.8452	0.5521	2.66	0.23
80	26.14	5.45	0.4915	0.3833	4.11	1.00
100	10.28	2.6	0.1212	22.00	1.84	
Foam height (cm)						
30	27.49	4.32	0.7081	0.3843	4.03	1.46
60	44.71	20.55	0.8452	0.5521	2.66	0.23
90	78.17	47.46	53	0.7610	1.98	0.09
Feed concentration (CMC)						
0.25	89.23	36.38	0.8434	0.7354	1.43	0.10
0.50	44.71	20.55	0.8452	0.5521	2.66	0.23
0.75	39.85	9.22	0.8312	0.4414	3.67	0.69
0.85	31.22	9.04	0.8755	0.4550	4.01	0.73
1.00	22.89	8.99	0.9081	0.4535	4.63	0.75
Number of trays						
1	5.59	1.44	0.9896	0.2351	23.69	2.49
2	18.41	2.38	0.8418	0.2343	7.36	1.89
3	44.71	20.55	0.8452	0.5521	2.66	0.23
4	51.35	22.40	0.8333	0.6463	1.07	0.20

^a Unless otherwise specified, base conditions were: air flow rate, 50 l/min; feed flow rate, 25 ml/min; foam height, 60 cm; surfactant feed concentration, 0.5CMC; temperature, 25 °C; number of trays, 3.

3.4. Effect of feed concentration

The effect of the influent surfactant concentration at different feed flow rates is shown in Fig. 11. As can be seen from this figure, an increase in CPC concentration leads to a decrease in the enrichment ratio but does not affect the removal fraction significantly. The wetness of the foam increases with increasing surfactant concentration since the surface tension is reduced by adding more surfactant resulting in more foam forming. An additional effect is that

a higher surfactant concentration in the thin liquid film in the foam lamellae may cause higher surface liquid viscosity leading to a decreased rate of film drainage. On the other hand, foam that is formed over a fluid with a low surfactant concentration is less stable and results in a much higher enrichment ratio than that formed over a higher surfactant concentration. In contrast, the foam formed over a fluid with a higher concentration is characterized by smaller, more stable bubbles. Similar results were observed in the previous study [11].

As evident from the experimental results obtained in the present study, in order to achieve high enrichment values, multistage foam fractionation is best used at lower surfactant concentrations.

3.5. Effect of number of stage

Fig. 12 shows the effect of the number of stages on surfactant separation efficiency. The results showed that for any given feed flow rate and air flow rate, the total removal fraction and enrichment ratio both increased with increased number of stage. This is understandable, since an increase in number of stages or increase the larger surface area for gas–liquid contacting leads to a greater surfactant mass transport out of the column with a longer foam residence time; hence the advantage for reaching higher enrichment ratio and yielding greater removal fraction. The number of stages required for previous experiment (batch process and single-stage column) at 90% reduction in concentration is 8 and the overall enrichment ratio is 21.5 [12]. The experimental results (continuous process and bubble-cap tray multistage column) give the overall enrichment ratio as 27.88 for three-stage systems. However, an increase in enrichment ratio as a result of the multistage treatment system shown in Fig. 12, is no significant improvement between the three- and four-stage systems. This result should not be solely dependent on an increase in number of stage but also related to the two concentrations C_f and C_e as the quasi-equilibrium of

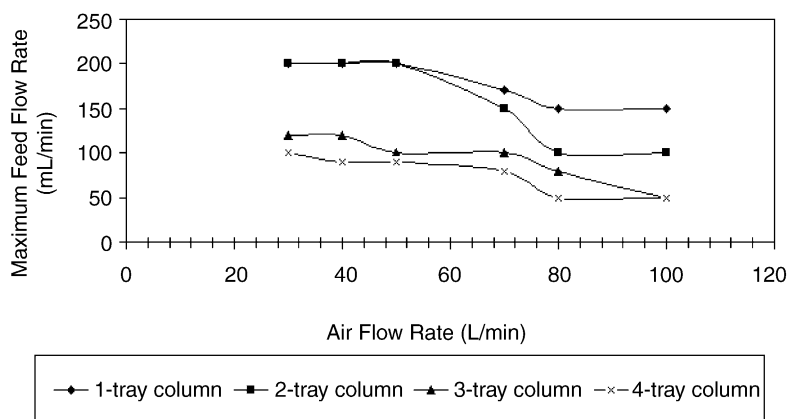

Fig. 9. Flooding points of each unit system of the foam fractionation column.

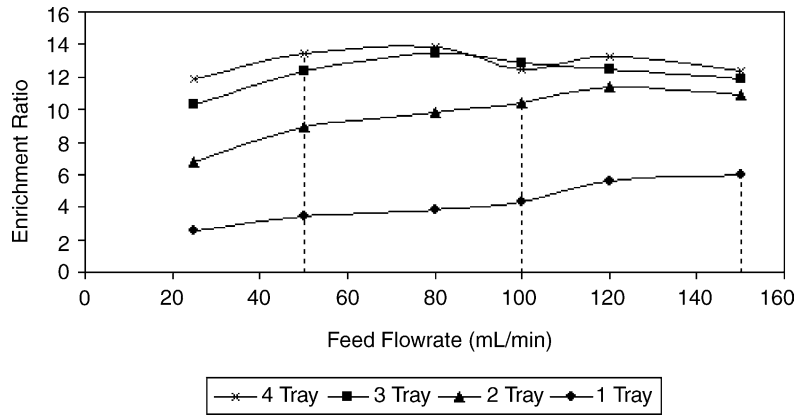

Fig. 10. Flooding points of each unit system of the foam fractionation column.

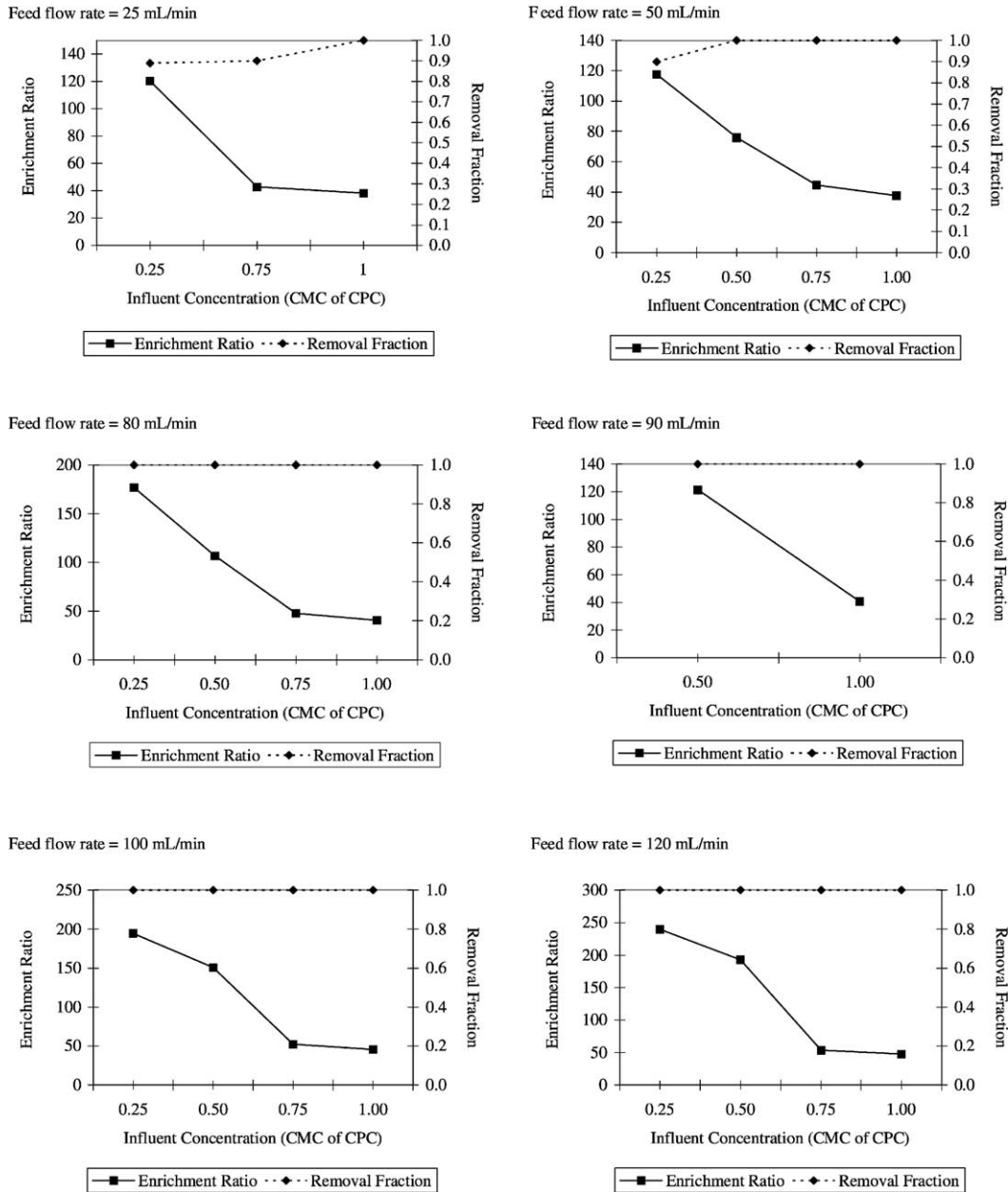

Fig. 11. The effect of influent surfactant concentration on surfactant separation efficiency at different feed flow rates (air flow rate, 301/min; foam height, 60 cm; and number of stages, 3).

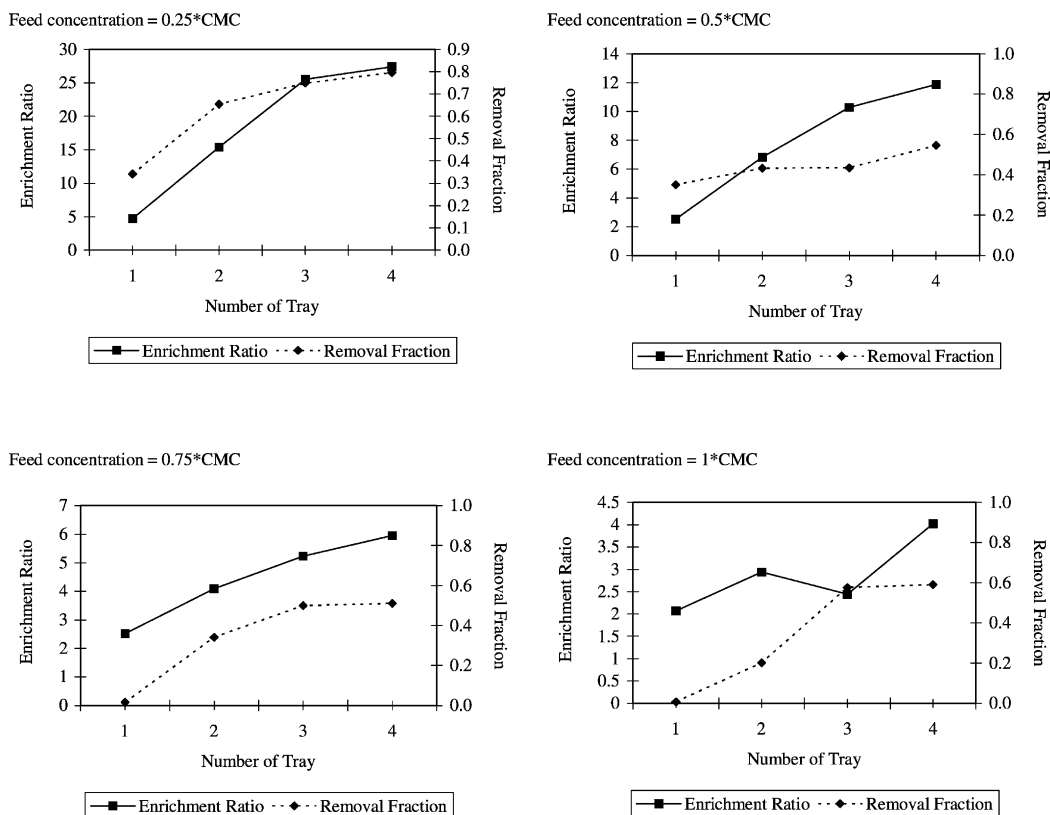

Fig. 12. The effect of number of stage on surfactant separation efficiency at different feed concentrations (air flow rate, 100l/min; foam height, 60 cm; and feed flow rate, 25 ml/min).

this particular fractionation column which is analogous to the countercurrent operation in distillation. Thus, the increase in the level of complexity with more than three stages is not justified.

In addition, to exhibit the performance of number of stage effectiveness, the experiments were set up for keeping the constant residence time for at one-, two-, three- and four-stage foam fractionation column. At the constant residence time, the enrichment ratio and the removal fraction are both increased with increasing number of stage as illustrated in Fig. 13. This result confirms that an increase the

number of stage results in improving both the enrichment ratio and the removal fraction.

3.6. Effect of type of surfactant

Two different surfactants were chosen for study: sodium dodecyl sulfate (a typical anionic surfactant), and cetylpyridinium chloride (a typical cationic surfactant) which show great promise in several surfactant-based separations [9].

Fig. 14 shows plots as a function of both actual variable parameters and type of surfactant as a fraction of the CMC in

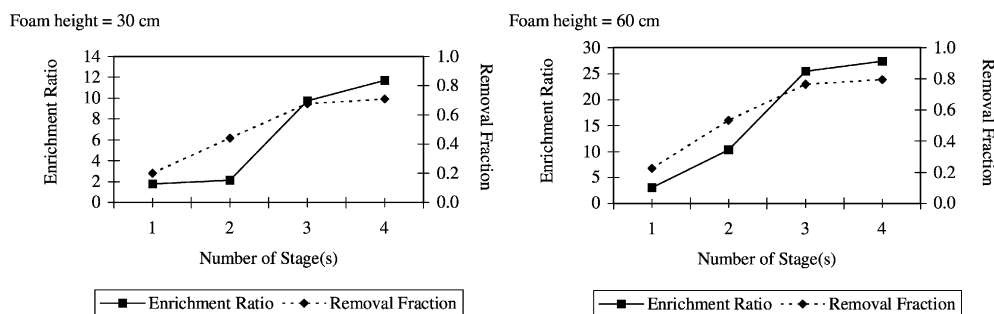

Fig. 13. The effect of number of stage on surfactant separation efficiency at constant residence time of 277 min (air flow rate, 100l/min; and feed concentration, 0.25CMC).

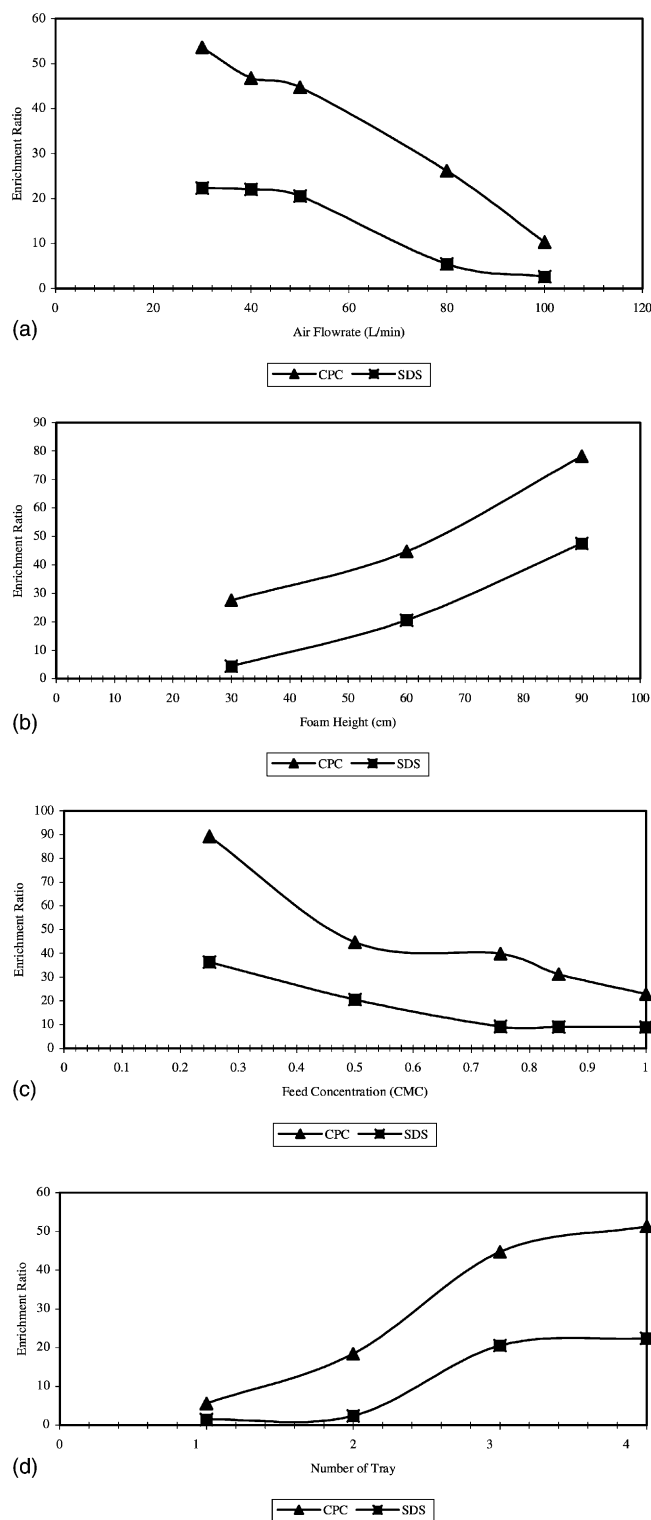

Fig. 14. Effect of surfactant type.

order to compare the behavior of different surfactant structures. The SDS exhibits a much dryer foam, a lower separation efficiency and has a substantially lower enrichment ratio than the CPC.

This confirms that CPC is the most readily removed of the two surfactants studied, as suggested from raw data earlier.

4. Conclusions

The multistage foam fractionation of rinse water containing surfactants was investigated in a continuous flow operation. The effects of important parameters such as influent concentration, air flow rate and foam heights on separation efficiency were investigated in multistage operation for cetylpyridinium chloride which is cationic surfactant on this preliminary results. The highest values of enrichment ratio of approximately 240 and removal fraction of 1 could be obtained for 25% of the CMC in the influent concentration with liquid residence time of 82 min which much higher enrichment ratio compared to that of the previous work in single stage, 21.5 in enrichment ratio and at liquid residence time of 375 min because of the difference in the column design. The relationship between the surfactant concentration in the effluent and concentrate streams was identified. The use of optimized specific air velocities and foam heights in multistage fractionation column resulted in an improvement in both removal degree and enrichment ratio. In this multistage situation operation, the removal degree and the enrichment factor for the surfactant load investigated leveled off the performance after three stages which depends on economics. The influence of operational parameters could be concluded as the followings:

- (1) An increase in the air flow results in a decrease in the enrichment ratio and an increase in the surfactant recovery.
- (2) A greater foam height produces a higher enrichment ratio and lower surfactant recovery rate.
- (3) Liquid height has little effect on the multistage separation process.
- (4) The enrichment ratio decreases and the surfactant recovery rate increases as feed liquid surfactant concentration increases.
- (5) An increase in the number of trays results in an increase in the enrichment ratio as compared to a single-stage fractionator, a multistage foam fractionator gives a higher yields of enrichment ratio.
- (6) The effectiveness of the foam fractionation process in recovering CPC is better than for SDS.

References

- [1] E.J. Chou, Y. Okamoto, *Sep. Sci. Tech.* 13 (1978) 439–448.
- [2] A.N. Clarke, R.D. Mutch, D.J. Wilson, K.H. Oma, *Wat. Sci. Tech.* 26 (1992) 127–135.
- [3] R.B. Grieves, R.K. Wood, *AIChE J.* 10 (1964) 456–460.
- [4] D.B. Hyma, A.I.A. Salama, *Miner. Process.* 86 (1993) 50–54.
- [5] K. Kumpabooth, *Sep. Sci. Tech.* 34 (1999) 157–172.

- [6] R. Lemlich, Adsorptive Bubble Separation Techniques, Academic Press, New York, 1972, pp. 152–157.
- [7] M.J. Rosen, Surfactants and Interfacial Phenomena, Wiley, New York, 1988 (Chapter 7).
- [8] J.F. Scamehorn, in: J.H. Harwell, Surfactant-based Separation Process, American Chemical Society, Washington, DC, 2000 (Chapter 1).
- [9] J.F. Scamehorn, in: J.H. Harwell (Ed.), Surfactant-based Separation Process, Part IV, Marcel Dekker, New York, 1989.
- [10] P.A. Schweitzer, in: Handbook of Separation Technique for Chemical Engineering, McGraw-Hill, New York, 1996 (Chapter 2).
- [11] W. Simmler, R. Stickel, Chem. Ing. Tech. 44 (1972) 341–347.
- [12] N. Tharapiwattananon, J.F. Scamehorn, S. Osuwan, J.H. Harwell, K.J. Haller, Sep. Sci. Tech. 31 (1996) 1233–1258.
- [13] D.J. Wilson, Sep. Sci. Tech. 23 (1988) 133–151.
- [14] S. Wangrattanasopon, J.F. Scamehorn, S. Chavedej, C. Saiwan, J.H. Harwell, Use of foam flotation to remove *tert*-butylphenol from water, Sep. Sci. Tech. 31 (1996) 1523.